

Biodegradable Surface Wipes

Technical product specifications, transport specifications and regulatory information



Product specifications:

Product code	BCW60PF
GTIN	Pack: 5060899541959 Display Box: 5060899545490 Carton: 05060899545506
PIP code	4219978
Wipe size (mm)	180mm x 190mm
Wipe GSM	45
Substrate material	100% viscose
Shelf life	2 years
Storage	Store in a cool, dry, well-ventilated place, away from direct sunlight. Do not allow to freeze. Keep container closed when not in use
Fragrance	Green Tea Perfume

Regulatory information and cautions:

Registration / classification	PTII & PTIV biocide
Indications for use	Wipes for cleaning and disinfecting surfaces & equipment
First aid cautions	<p>Inhalation: Acute effects following exposure to this product via the inhalation route are not anticipated during normal handling and use.</p> <p>Skin: This product is not intended for use on skin. If skin irritation occurs, seek medical advice.</p> <p>Eyes: Should eye irritation be experienced, this effect would likely be transient. But should symptoms persist, seek medical advice.</p> <p>Ingestion: This product is for external use only and should be kept away from children. No adverse effects are anticipated from the formulation via the oral route during normal handling and use of the product.</p>
Hazards identification	Harmful to aquatic life with long lasting effects

Product transport specifications:

Packaging information	
No. of wipes per pack	60
Pack dimensions	256mm x 96mm x 35mm
Pack weight	375g
Primary packaging composition (flow wrap & label)	Polypropylene
Packs per unit	12
Unit dimensions	250mm x 230mm x 255mm
Unit net weight	4.510kg
Unit gross weight	5.250kg
Max stowage	Double stack pallets in static storage or transport
Pallet configuration	
Unit per layer	20
Packs per layer	240
Pallet size	1170mm x 1000mm
Pallet height	1164mm
No. of pallet layers	4
Units per pallet	80
Packs per pallet	960

Diagram

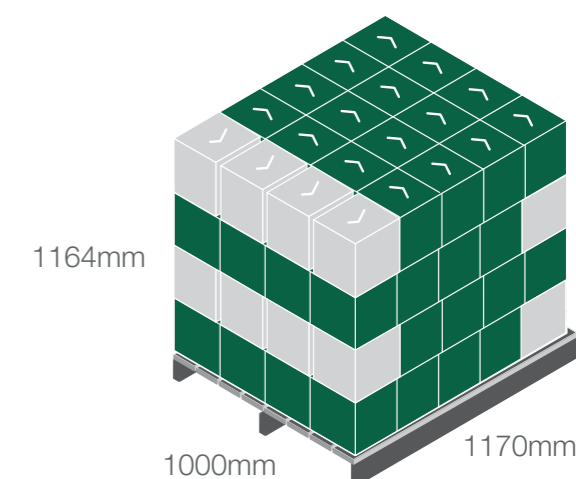

Active ingredients:

Alkyl (C12-16) dimethylbenzyl ammonium chloride	0.27g/100g
Didecyldimethylammonium chloride	0.27g/100g

For more information, speak to your GAMA Healthcare Area Manager or visit www.clinell.com



Clinell Biodegradable Wipes are proven to biodegrade in active landfill conditions, in accordance with ASTM D5511-18 standards.

Tested and verified by an accredited, third-party laboratory according to international standard ASTM D5511. Clinell Biodegradable Surface Wipes biodegrade under simulated landfill conditions (anaerobic) within 15 days.

Use biocides safely. Always read the label and product information before use.