

Instant patient isolation

Wherever it's needed

PRODUCT BROCHURE



“The problem is that there is no easy isolation. With Rediroom you can create an effective isolation area and retain the flexibility to move it around anywhere. There’s no other product on the market that can do that.”

Dr. David Cooksley

Senior Emergency and Retrieval Physician –
Royal Brisbane & Women’s Hospital

REVOLUTIONARY DESIGN, RUGGED CONSTRUCTION

An 8-year collaboration between industrial designers, clinicians and infection prevention experts.

HEPA & carbon air filtration

Filters 99.5% of particles from infectious air

Raiseable window blinds

Lower for patient visibility or raise for privacy

Integrated PPE station

Everything you need, always at hand

Hands-free entry and exit

Reduce the risk of contact-spread infection

Easy decontamination

Collapsible canopies and easy-to-clean frame combine to allow effective terminal clean

Wall-to-floor seal

Isolate patients under contact and droplet precautions

Room to manoeuvre

Care for patients just like in a standard bed space¹

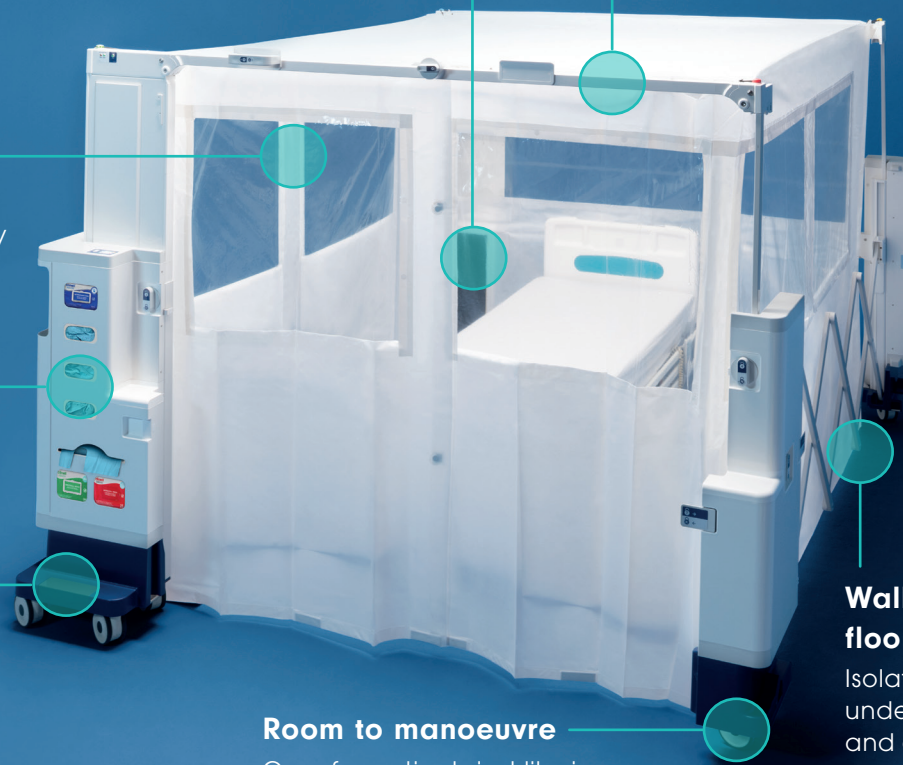

Scan me!

See Rediroom in action

FULLY OPERATIONAL IN LESS THAN 5 MINUTES

Suitable for:

- ✓ Contact Precautions
- ✓ Droplet Precautions

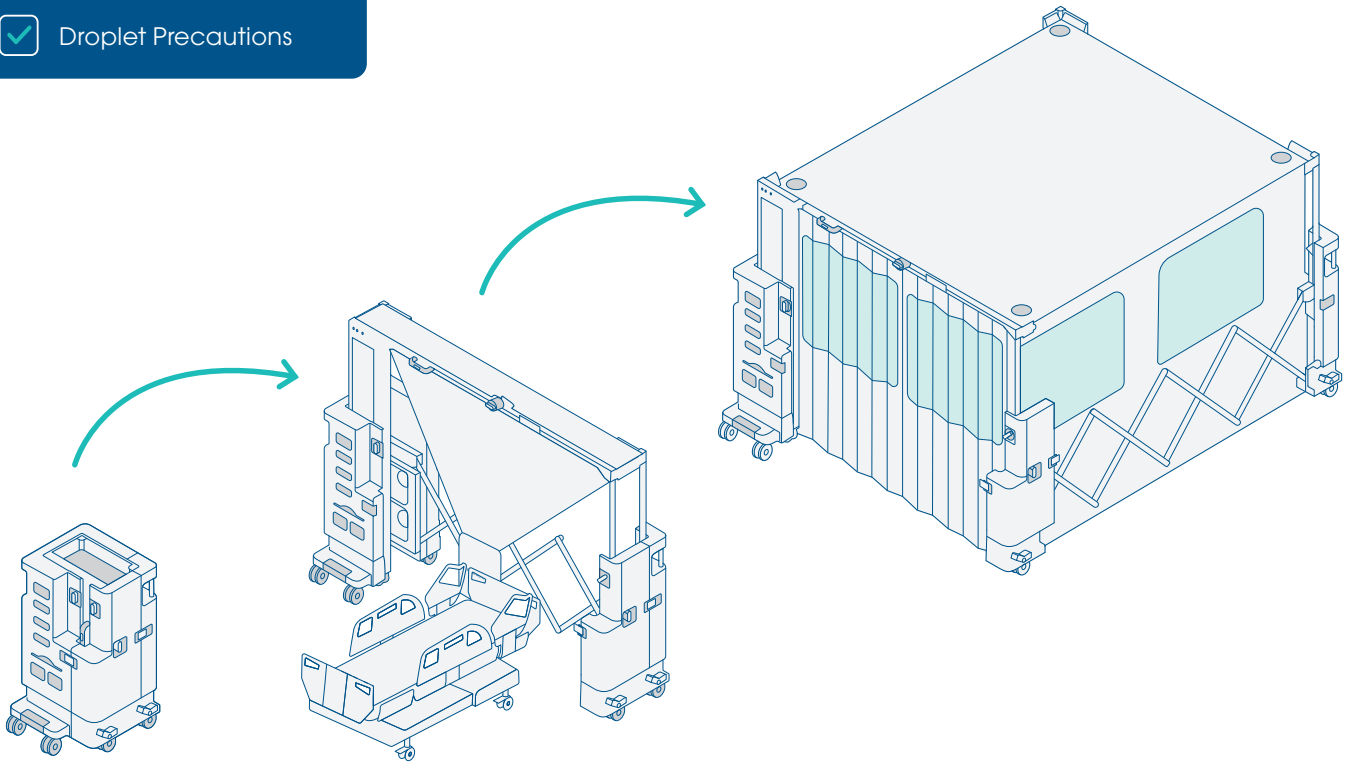

Rediroom, before assembly

Rediroom equips hospitals to isolate patients in a new way: by bringing the isolation room to them.

Assembled around a bedspace, by a single person, in less than 5 minutes.

Conforms to multinational infection prevention guidelines², providing effective contact and droplet isolation.

STOPPING THE SPREAD OF INFECTION

Rediroom contains an array of features to protect patients from contact or droplet pathogens.

Droplet spread (droplet precautions only):

Droplets spread up to a two-meter radius when colonised patients cough, sneeze or talk. Rediroom provides a physical barrier, as well as HEPA filtration to remove infectious droplets from the air before they return to the ward.

Rediroom contains a high-grade H12 air filter, that traps 99.5% of particles from as small as 0.3 micrometres. That's fine enough to physically trap bacteria, and efficient enough to filter more particles than an N95 respirator.

Common droplet pathogens include influenza, diphtheria, mumps, pertussis and meningococcus.

Direct & indirect contact spread (droplet and contact precautions):

A host of pathogens can spread via direct contact (typically through contaminated hands) or indirect contact (involving contaminated surfaces).

Placing infectious patients within a Rediroom creates a physical separation to disrupt direct contact. The hands-free entry and exit helps reduce hand contamination. In-built PPE station promotes best practice, putting protective equipment, hand hygiene and surface disinfectants all at the point of use.

Common contact pathogens include MRSA, *C.difficile*, CPE and other MDR Gram-negative organisms.

Figure 1: shows the common routes of spread for droplet and contact pathogens. Pathogens can spread via droplets, contaminated hands (direct contact) or contaminated surfaces (indirect contact). Adapted from Otter et al³

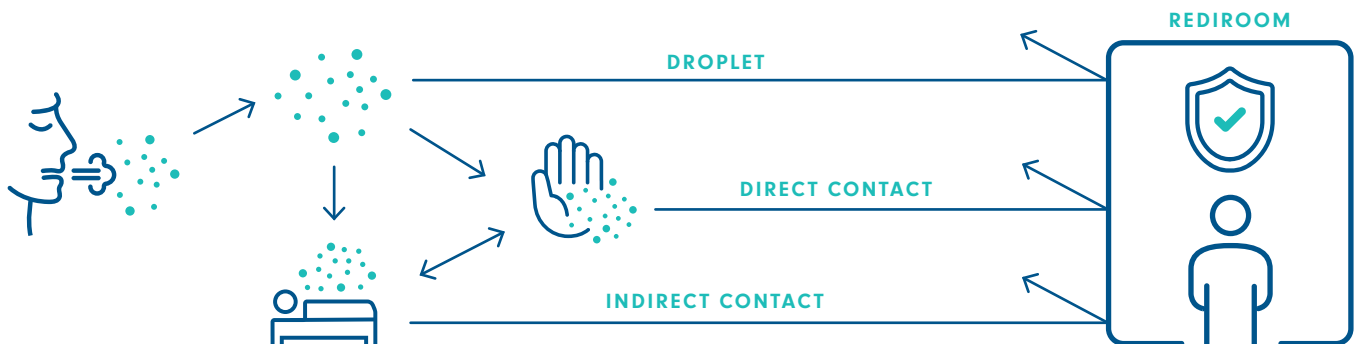

CARE AND CAPACITY

Rediroom provides ample space for staff to carry out patient care.

When used on a ward, staff were able to perform tasks just as they would in a standard bed space on an open ward¹.

In addition, Rediroom can be deployed in a range of situations:

Hospital settings

Multi-bed wards, emergency departments, ICUs, dialysis departments, ambulatory day care units, recovery units, triage areas.

Other settings

Aged-care settings, outbreak situations, airports and military facilities.



Inside Rediroom, easy patient care

About GAMA Healthcare

Rediroom is designed and developed by GAMA Healthcare – infection prevention specialists, and providers of Clinell Universal Wipes.

For more information, a product demonstration, or advice about how you could implement Rediroom in your organisation, speak to your local GAMA Healthcare Sales Manager, or visit rediroom.com.au

Product codes:

Product	Code*
Rediroom Cart	RED1TAUS
Rediroom Canopy	REDICAN1AUS
Rediroom Canopy (small)	REDICAN1AUS-S40

* Please contact your local GAMA representative for the Rediroom Cart product code for your country.

References:

- ¹ Mitchell et al. *Am J Infect Control*. 2017;45(11):1231-7
- ² Mitchell et al. *Infect Dis Heal*. 2017;22(3):129-135.
- ³ Otter et al. *J Hosp Infect*. 2016;92(3):235-250.



GAMA Healthcare Australia Ltd.,

Suite 1, 33-37 Duerdin Street, Notting Hill, VIC 3168, Australia.

T: +61 (0)3 9769 6600 **E:** info@gamahealthcare.com.au

gamahealthcare.com.au/rediroom

GHA2010011